

Ride-Through Topology for Adjustable Speed Drives (ASD's) During Power System Faults

S.S.Deswal, Senior Lecturer, Maharaja Agrasen Institute of Technology, Rohini, Delhi, satvirdeswal@hotmail.com

Ratna Dahiya, Assistant Professor, NIT, Kurukshetra, Haryana, ratna_dahiya@yahoo.co.in

D.K.Jain, Assistant Professor, DCRUST, Murthal, Haryana, jaindk66@gmail.com

Abstract

Adjustable Speed Drives are susceptible to voltage sags occurring due to faults in electric power system. There are different techniques to enhance ride-through capability of ASD's during voltage sag conditions. These are aimed at maintaining the DC-link voltage constant by injecting energy from an external source. Ultracapacitors, as storage device, are of reduced size as compared to batteries and provide fast energy exchange. In this paper, the improved performance of ASD's with Ultracapacitors at DC-link during various electric power system faults is demonstrated using MATLAB simulation.

Index Terms

Ride-through topologies, Electric power quality, Adjustable speed drives, Ultracapacitors.

Introduction

Electric power quality encompasses voltage transients, sags, swells, voltage distortions and momentary interruptions (outages) etc.[1-7,11]. The situation of poor power electric quality is more evident in countries with a weaker power grid, such as India, African countries, and other developing countries, than in the industrialized world. Nevertheless, the problem is of significance also in countries with a strong power grid. The voltage sags affect many systems and in particular, sensitive equipment, for example Adjustable-speed electrical drives (ASD's). The voltage sag event even of a small duration leads to the shutdown of the industrial drive and the process stops, leading to lost time, material and financial losses. ASD's are therefore made to tolerate the uncertainty of the power supply with variations in the voltage. The basic configuration of an alternating current ASD's is shown in Fig. 1. The AC source voltage is rectified to DC forming a DC-link. The DC link voltage is converted to AC supply of desired voltage and frequency to feed AC motor. An electrolyte DC capacitor is placed at DC-link. The capacitor is charged when the instantaneous voltage on the AC-source is higher than the DC-link voltage. A current then flows from the AC-source to the capacitor and the DC-link voltage increases. When the DC-link voltage is equal to the voltage on the AC-source the current decreases to zero. The load is then fed from the capacitor and the DC-link voltage decreases until the AC-source voltage is greater than the remaining DC-link voltage. In steady-state there are six current pulses on the DC-source per cycle. The various factors determining the performance of AC motor drives during voltage sags are: sag magnitude variation, sag duration, sag asymmetry, phase jump, non-sinusoidal wave shapes [8-9]. The main reasons for AC drive tripping during voltage sag are: DC-link undervoltage/overvoltage, drop in speed of motor, and increased AC currents during sag or post-sag, and finally over current charging of the DC-link capacitor.

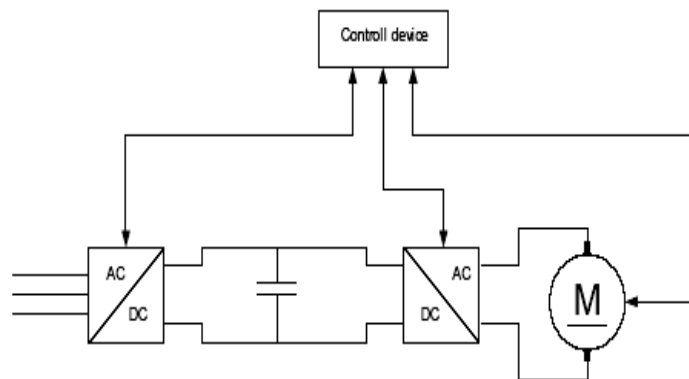

Fig. 1. AC ASD'S topology

Different Types of Voltage Sags and Impact on ASD's

Due to different kinds of faults in power systems, different types of voltage sags can be produced. Voltage sags are divided into seven groups as type A, B, C, D, E, F and G. Type A is symmetrical and the other types are known as unsymmetrical voltage sag. The most common voltage sags are types A, B, C and D. The following are the characterization of A, B, C and D sags. Type A is produced because of three phase faults, which produces a voltage reduction in the three phases of the electrical system, see Fig. 2(a). Type B is due to single phase faults and it produces a voltage reduction in one phase of the electrical system; see Fig. 2(b). Type C is due to phase to phase faults and it produces a voltage reduction in two phases of the electrical system together with phase-angle jumps, as it is shown in Fig.2(c). The voltage sag D is defined by a voltage drop in one phase, and the angle between the other two phases is more than 120, see Fig.2 (d).

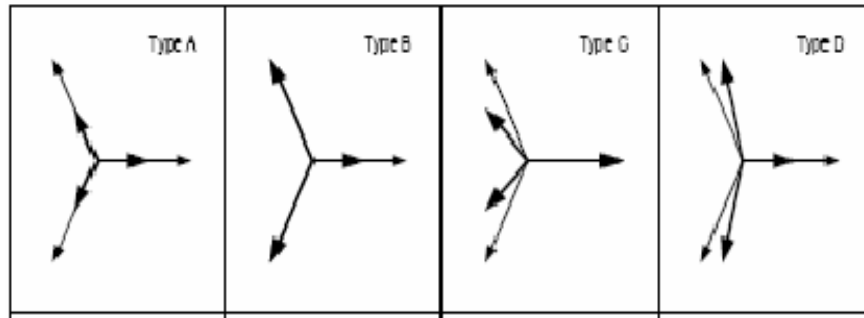

Fig. 2 Different types of sags: (a) type A (b) type B (c) type C (d) type D

During a voltage sag the voltage on the AC-source is reduced. Depending on the type and duration of the voltage sag, the voltage on the DC-link changes. Voltage sag of *Type A* occurs because of balanced three-phase faults or power failure and it results in the reduction of the voltage on the DC-link that is proportional to the AC-source voltage. This type of voltage sag is the most severe. The under-voltage or over current-protection on the DC-link may trip the ASD's. If the voltage sag is of *Type C*, the circuit will behave as a single-phase rectifier. Even 10% voltage sag will result in a single-phase operation of the three-phase diode rectifier [3, 4, 6, 11]. The voltage between the two non faulted phases is un-affected and the DC-link voltage will not be reduced. The current pulses, however, will be changed. The same amount of energy must be transferred, but now in two pulses instead of six. The peak value of the current will be 200% larger, and may cause an over-current or a current unbalance. The over-current or unbalance protection may trip the ASD's. A phase angle jump will affect the phase voltages and the DC-link voltage.

The sensitivity of AC ASD's to voltage sags is presented in a voltage tolerance curve as shown in Fig. 3 as per IEEE Std. 1346[2]. It may be seen that the ASD's can withstand a reduction in the line voltage upto 85% of nominal value for an extended duration of time. This figure may change, depending on the sensitivity of the process controlled by the drive. For all points falling below the voltage tolerance curve, the drive will trip [9-10]. In all AC drives, the output DC voltage is smoothed by a capacitor. The tripping of the drive takes place on detection of a DC under-voltage or over-current situation resulting from sag. When a sag event occurs, the output voltage V at a time t is given by

$$V = \sqrt{(V_0^2 - (2P/C)t)}$$

Where, V_0 is the voltage before the event. P is the load connected to the output bus. Varying the capacitance C , the time for the drive to trip may be varied. It is clear that the immunity against voltage sags can be improved by adding more capacitance to the DC-link.

For a sag of *Type C* of magnitude 50%, the DC-link voltage does not drop below 70%, even for a small capacitance. This is because there is at least one phase that is still at 100% magnitude, and this phase stabilizes the DC-link voltage. In the case of sags of *Type D* of magnitude 50%, there is no such phase and, therefore, the effect is more harmful on the DC-link, although not as much as in a balanced sag case. For unbalanced sag events, even a small capacitance prevents the DC-link voltage from dropping below 80% of rated voltage [1, 5]. The ability to ride-through voltage sag depends also on the DC-link energy storage capacity, the speed and inertia of the load, the power consumed by the load, and the trip-point settings of the drive. The most frequent ASD's trips are due to the undervoltage protection of the DC-link.

5HP ASD (PWM) Voltage Sag Tolerance Curves

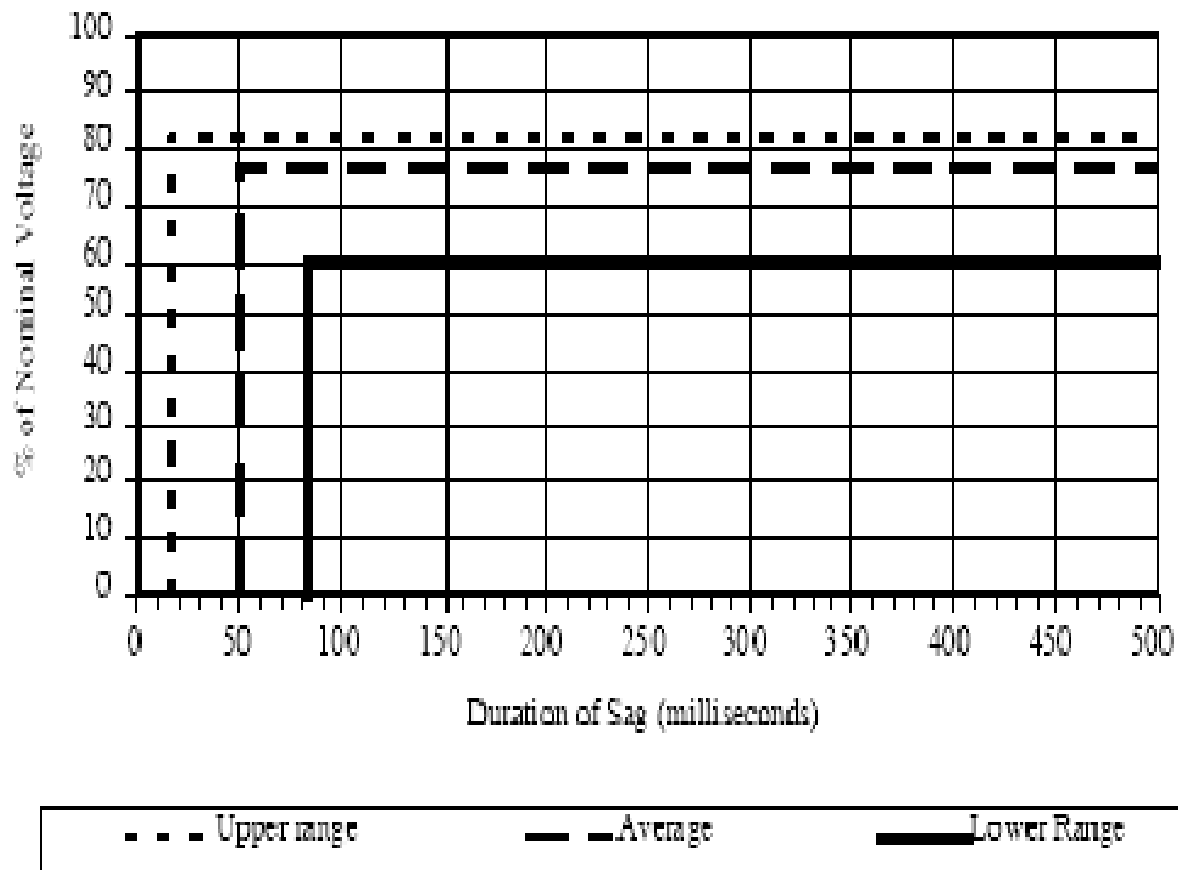

Fig. 3 Voltage tolerance curve of an ASD's (IEEE Std.1346)

Different Ride-Through Alternatives

By adding capacitors to the DC- link, additional energy needed for full-power ride-through during voltage sag can be provided to the motor. It is a simple and rugged approach, which can provide limited ride-through for minor disturbances. However, its cost is relatively high and a large cabinet space is required. The load inertia may be utilized to provide ride-through capability to ASD's. The inverter control software can be modified such that when a power disturbance causes the DC- link voltage to fall below a specified value, the inverter will adjust to operate at a frequency slightly below the motor frequency, causing the motor to act like a generator. The drive will absorb a small amount of energy from the rotating load to maintain the DC- link at a specified level and maintains the specified DC- link for few seconds during a dip that does not exceed 20%. Here, no additional cost is included only small software modification is required but provides ride-through only for sags of 20% and reduced speed may not be acceptable for certain loads[7-8].

Since the DC- link current varies with the frequency of the drive for variable-torque loads, such as fans and pumps, a reduction in the motor speed will result in a reduction in the DC- link current. Therefore, a fan and pump system running at 40 Hz will draw less current than a system running at 50 Hz and will, therefore, be able to operate for a longer period during a voltage sag situation. It provides ride-through without any additional hardware and cost but application may not tolerate reduced speed operation. A boost converter can be used between the rectifier and the DC- link capacitors to maintain the DC- link voltage during voltage sag. During voltage sag, the boost converter will sense a drop in the DC-link voltage and begin to regulate the DC- link to the minimum voltage required by the inverter. Boost converter provides ride-through with lower cost, upto 50% sag but fails during outages. Replacing the

diode rectifier with an active PWM rectifier regulates the DC- link which offers immunity to voltage sags and transients and low input current harmonics. The range of ride through provided by this approach is limited only by the current rating of the rectifier. Active rectifier with lower cost provides ride-through up to 50% sag but fails during outages. Battery backup systems operate similarly to adding capacitive energy storage, with the advantage that their energy per volume ratio is much higher than standard capacitors.

The ASD's may be provided with battery backup as an add on module on the DC- link. The batteries are easily available with low cost, provide ride-through for deep sags and full outages [5]. These have low life and require additional space and maintenance. Flywheels, which store kinetic energy in a rotating mass, are also showing promise for ASD's ride-through. Flywheels are suitable for 1 kW–10 MW applications, and can provide full-power ride-through for up to 1 hr. Superconducting Magnetic Energy Storage (SMES) is based on the principle that energy stored in the field of a large magnetic coil can be converted quickly back to electric current as needed for various applications. A SMES unit can be applied directly connected to the DC- link of ASD's or to a number of ASD's which share a common DC- link. SMES with little maintenance provides good ride-through for long duration but it is costly and requires sophisticated cooling system to maintain cryogenic temperatures and the associated power loss. A fuel cell could be interfaced with the ASD's DC- link to provide appropriate backup power for an individual. However, the fuel cells are costly and may be used in near future [5, 8, 10].

Ultracapacitors are new generation energy storage devices, which are true capacitors in the sense that energy is stored via charge separation at the electrode-electrolyte interface, and they can withstand a large number of charge/discharge cycles without degradation. The major advantages of Ultracapacitors include higher capacitance density, higher charge-discharge cycles, reliable, long life, and maintenance-free operation, environmentally safe, wide range of operating temperature, high power density and good energy density, so they are a good alternative. Ultracapacitors fill the gap between standard batteries and traditional capacitors for high-power, short-duration energy storage [5].

Comparison of different ASD's Ride-through Alternatives

Ultracapacitors offers many advantages for providing ride-through capabilities as given in Table -I [15].

Table-I Comparison of different ASD's Ride-through Alternatives

| ASD Ride- Through Alternatives | Cost Rs./KW | Ride-Through Duration Limit | Power Range | Efficiency | Cycle Life | Charging Time |
|--------------------------------|-------------|-----------------------------|-------------|------------|------------|---------------|
| Additional Capacitors* | 30000 | 0.1sec. | 100kw | 95% | 10000 | Seconds |
| Load Inertia | ≈0 | 2.0 sec. | 1kw-1mw | --- | --- | Continues |
| Reduced Speed/Load | ≈0 | 0.01 sec. | 5-10kw | --- | --- | --- |
| Lower Voltage Motors* | ≈0 | 0.01 sec. | 5-10kw | --- | --- | --- |
| Boost Converter** | 5000-10000 | 5.0 sec. | 5-200kw | 90% | --- | --- |
| Active Rectifier** | 5000-10000 | 5.0 sec. | 5-200kw | --- | --- | --- |
| Battery Backup* | 5000-10000 | 5.0 sec.,1hr. | 5kw-1MW | 70-90% | 2000 | Hours |
| Ultra Capacitors* | 15000-20000 | 5.0 sec. | 5-100kw | 90% | 10000 | Seconds |
| Motor-Generator Sets* | 10000-15000 | 15.0 sec. | 100kw | 70% | --- | --- |
| Flywheels* | 10000-15000 | 15.0 sec.,1hr. | 1kw-10MW | 90% | 10000 | Minutes |
| SMES* | 30000-40000 | 10.0 sec. | 300-1000KW | 95% | 10000 | Minutes-hours |
| Fuel Cells* | 75000 | 1 hr. | 10kw-2MW | 40-50% | continues | continues |

* provides Full-power ride-through

** provide full-power ride-through for single-phase sags<50%

Design Considerations of Ultracapacitors For ASD's

ASD's can be designed with integrated Ultracapacitors, or an add-on module on DC-link. With a lead-acid battery, voltage decreases about 20% between full-charge state and essentially 100% discharged state. In an Ultracapacitors, extracting 75% of the energy requires a 50% decrease in the capacitor voltage. The length of voltage disturbance that can be effectively compensated will depend on the energy density of the DC storage device. The majority of voltage disturbances on the distribution bus are for short duration, and mostly not lasting for more than 10 cycles [11-13]. The Ultracapacitors have sufficient storage capabilities and possess a fast discharge time thereby able to respond quickly to voltage disturbances, where as batteries are generally not suitable for short duration, fast response applications such as the STATCOM or DVR, because fast battery drainage effects considerably the device life. Energy stored in the capacitor is given by the following equation:

$$E = \frac{1}{2} CV^2$$

Where, C is the capacitance in farads, V is the voltage in volts, E is the energy in joules

$$\text{Usable Energy} = \frac{1}{2} C [(V_1)^2 - (V_2)^2]$$

Where, V_1 is the rated charging voltage V_2 is the rated minimum operating voltage of Ultracapacitors.

Improved Performance of Adjustable Speed Drives During Fault Conditions

In order to compensate the voltage sags at the DC-link of ASD's boost converters can be used along with Ultracapacitor as an energy storage device. These are connected in parallel with the DC-link as shown in Fig. 4(b). Once the voltage sag takes place, the boost converter regulates the DC-link voltage to a preset DC-link voltage (the minimum safe voltage limit or higher, depending on the application). It is capable of providing ride-through for voltage sags up to 50%. This technique is able to provide ride-through during an outage or during symmetrical or unsymmetrical. Hence, the ASD's remains in running mode during the disturbance [14-15].

Results and Discussion

To study the improved performance of ASD's, MATLAB Simulink Power System Block-set Toolbox Demo was modified as shown in Fig. 4. The ASD's is a direct torque controlled (DTC) induction motor (specifications are given in Appendix) and is having an integrated Ultracapacitors at DC-link. The objective of this section is to investigate the performance of an ASD's under various power system faults. Figs 5-7 show the performance of the proposed scheme. The parameters V_{abc} , I_{abc} , T_e , N_r , V_{dc} show the three- phase source voltages, line currents, electromagnetic torque, rotor speed, and DC-link voltage respectively.

Performance of ASD's during Three-Phase Symmetrical Fault

Fig. 5 shows the behavior of ASD's with a symmetrical fault. It can be seen that during the sag conditions, there is no source current being drawn since the DC-link voltage remains higher than the line voltages. The ASD's ride-through and runs with desired torque and the speed with constant DC-link voltage.

Performance of ASD's during Three-Phase Unsymmetrical Fault

Fig. 6 and Fig. 7 show the behavior of ASD's with an unsymmetrical fault (single line to ground fault and double line to ground fault). The source currents are unbalanced. The machine becomes unstable with large variations in DC-link voltage, which are reflected in the torque pulsations. With the application of Ultracapacitors, the performance of the machine improves having small torque pulsations. However, the three phase rectifier slips into the single-phase operation during the sag period.

Discrete
 $t_s = 1e-006$ s
 powergui

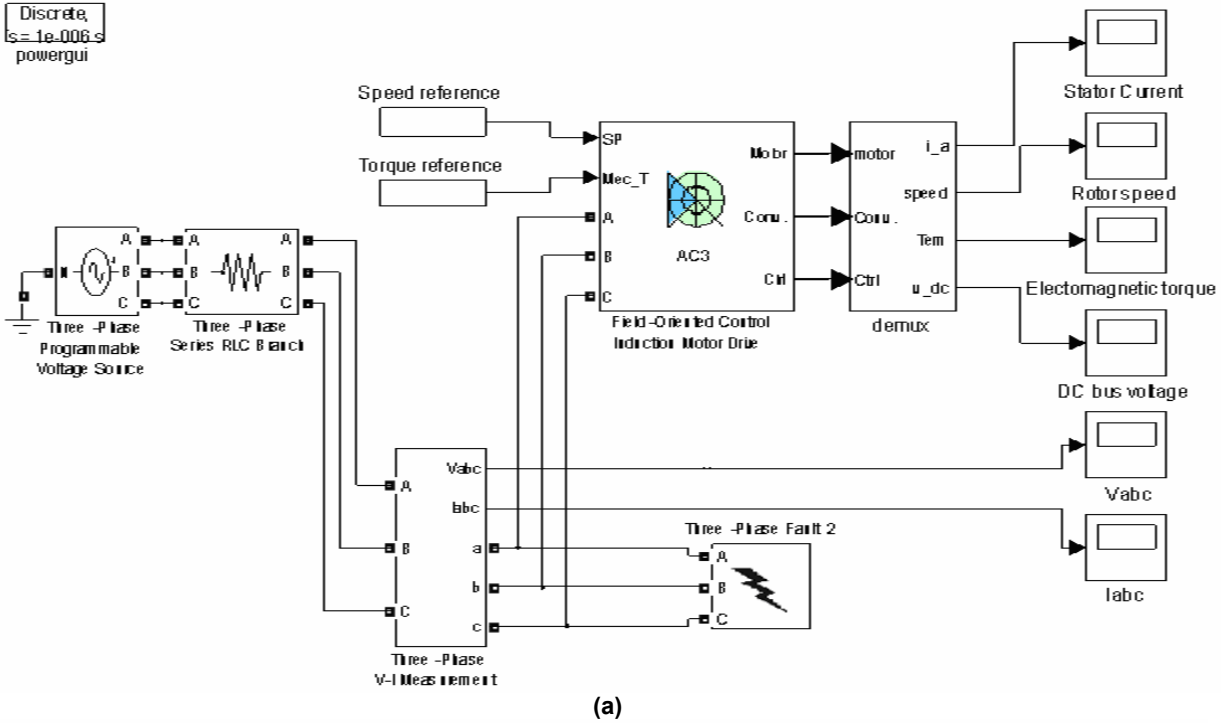

(a)

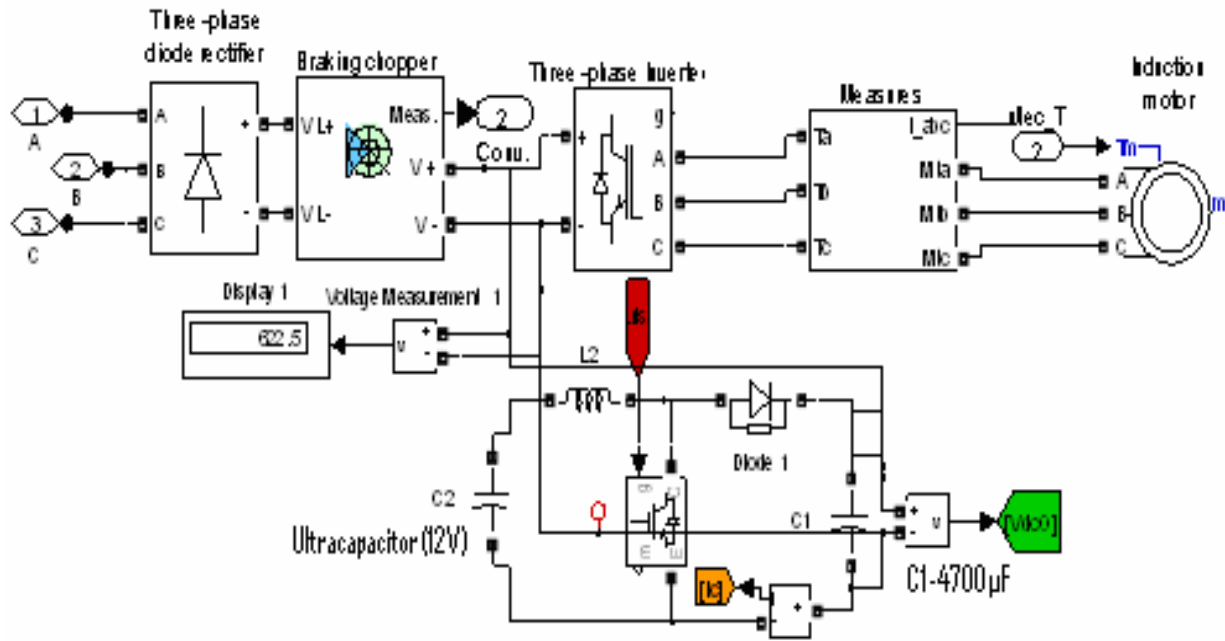

(b)

Fig. 4. MATLAB simulation of ASD's with Ultracapacitor at DC- link
 (a) System Simulation
 (b) Drive supply details with DC-DC boost converter with Ultracapacitor

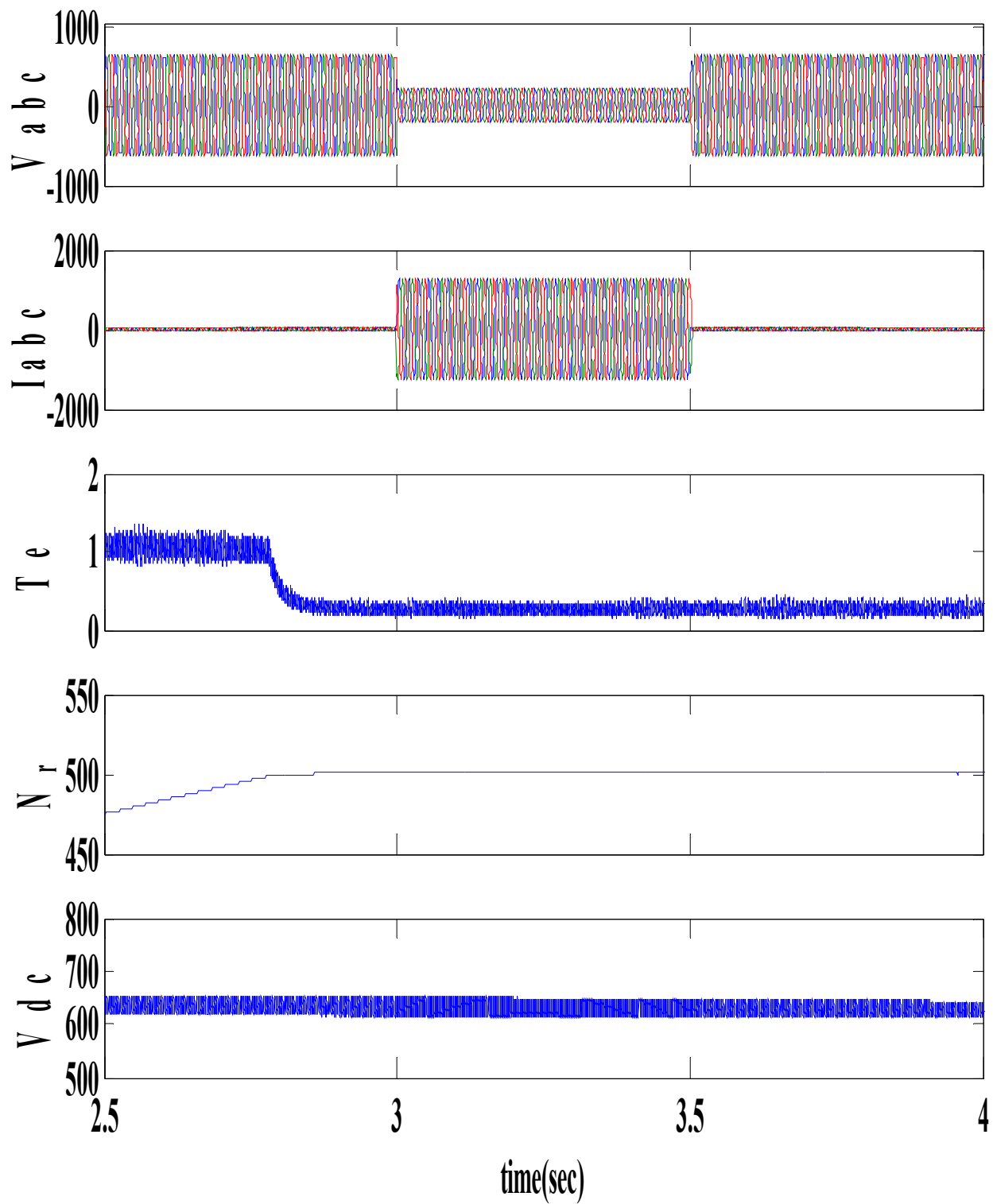

Fig. 5. Performance of ASD's during three-phase symmetrical fault

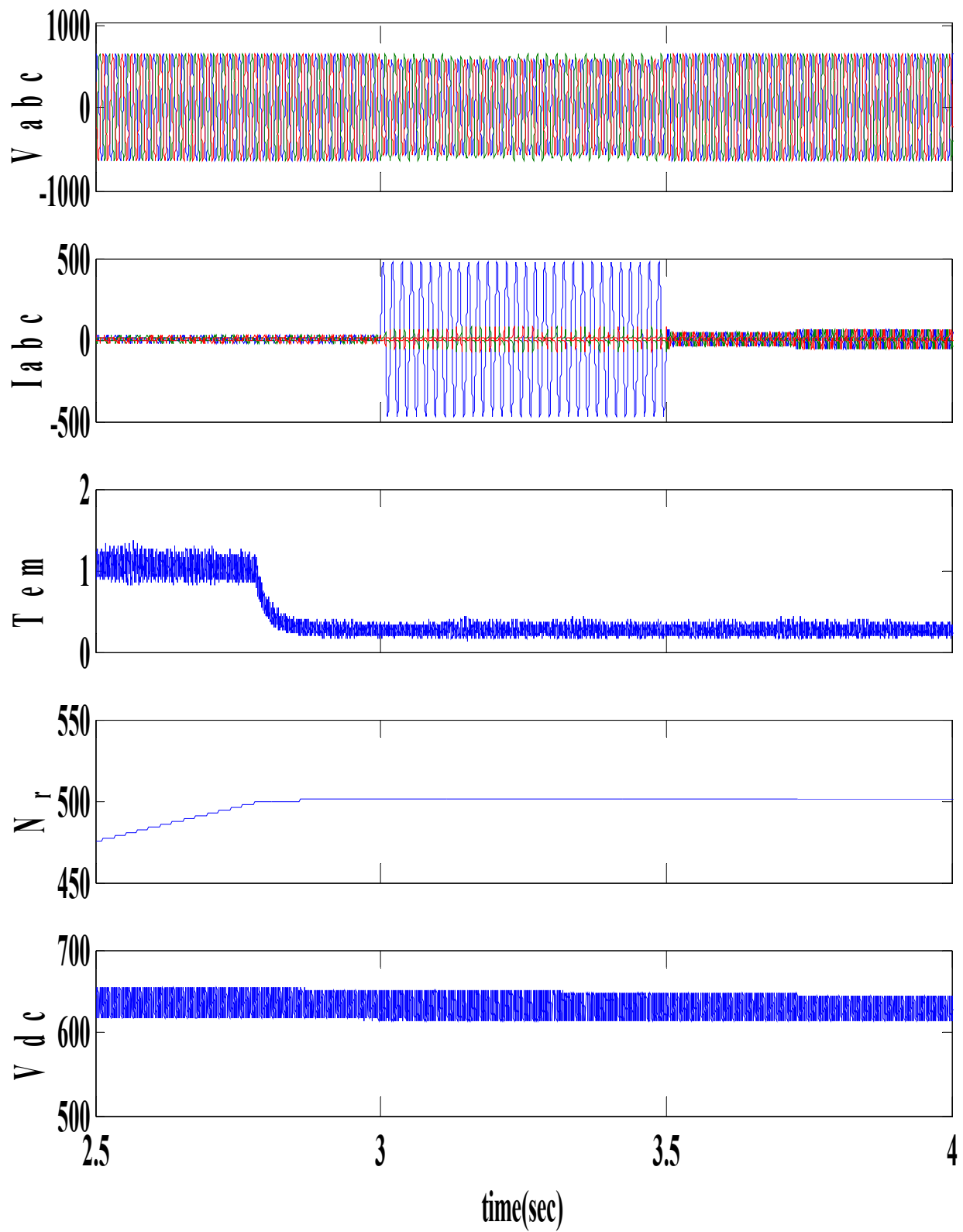

Fig. 6. Performance of ASD's during single-phase line -ground fault

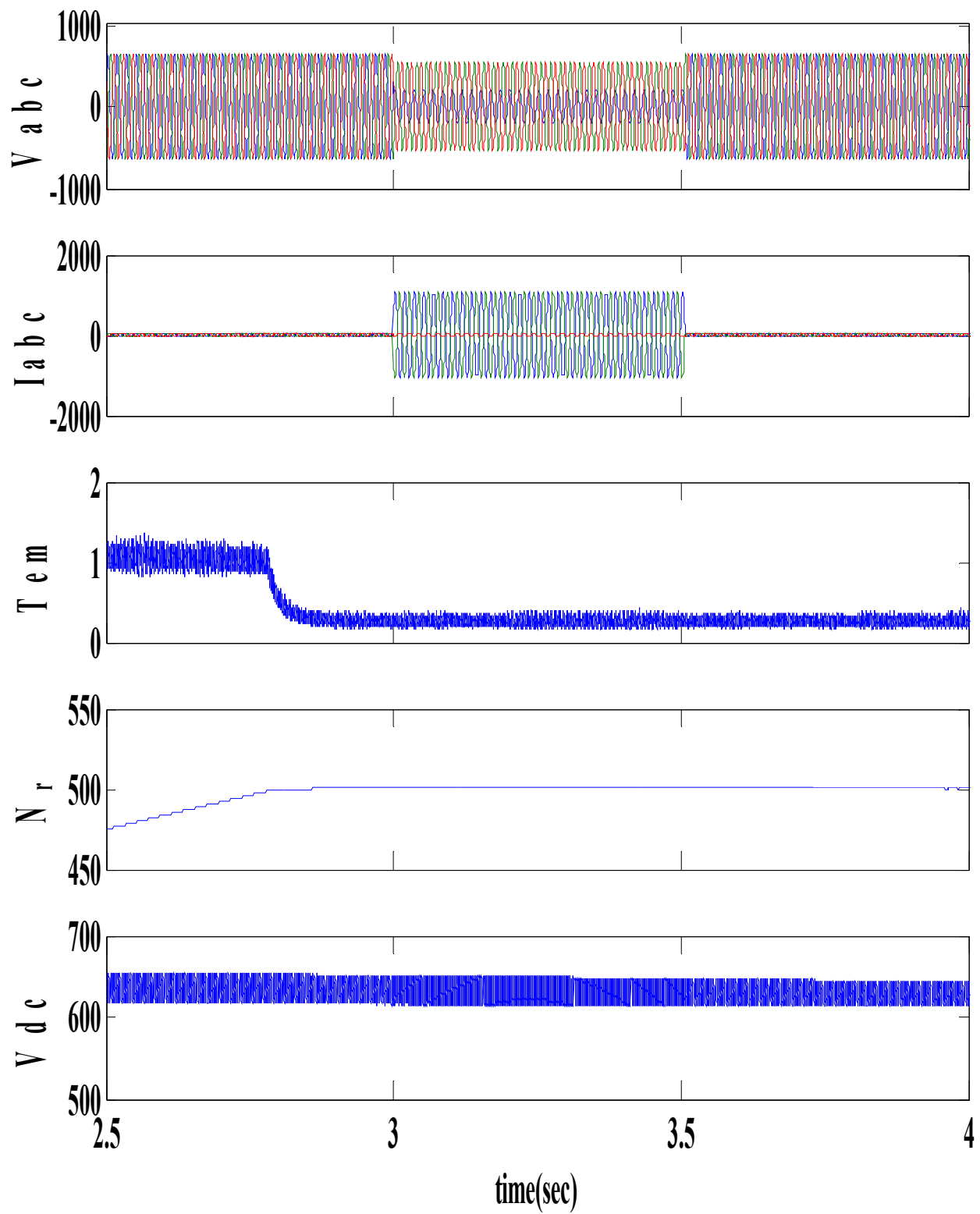

Fig. 7. Performance of ASD's during double line -ground fault

Conclusions

Ultracapacitors offer higher energy density compared to conventional capacitors due to its design and the new manufacturing technology used in it. A DC-to- DC converter is needed in order to interface the energy storage. During sag or outage conditions, the DC-link voltage decreases with time, hence, the importance of the DC-DC converter arises. In addition, the DC-DC converter is also responsible for pre-charging the capacitors slowly to avoid excessive current drawn from the supply during the normal operation which might cause damage to the input rectifier. The application of Ultracapacitors with a DC-DC converter leads to ride- through capability of ASD's.

Appendix

Induction Motor rating and parameters:

| | | |
|---|---|-------------------------|
| 124.3 kW, 415 volts(L-L), 3- Phase, 4 Poles, 60 Hz, 1450 rpm. | | |
| Stator resistance | = | 0.015 ohm, |
| Stator leakage reactance | = | 0.095 ohm, |
| Rotor resistance | = | 0.009 ohm, |
| Rotor leakage reactance | = | 0.095 ohm, |
| Magnetizing reactance | = | 4.584 ohm, |
| Rotor inertia | = | 3.1 kg.m ² . |
| DC- link capacitor: | = | 300F, |
| DC- link voltage | = | 620 volts |

References

1. IEEE Recommended Practices on Monitoring Electric Power Quality, IEEE Std.1159, 1995.
2. IEEE Recommended Practices for Evaluating Electric Power System Compatibility With Electronic Process Equipment, IEEE Std.1346, 1998.
3. M. H. J. Bollen, "Understanding Power Quality Problems: Voltage Sags and Interruptions", Series on Power Engineering. New York: IEEE Press, 2000.
4. G.T. Heydt, Electric Power Quality, 2nd ed. WestLafayette, Stars in a Circle, 1994.
5. A. Von, P.N. Enjeti, B. Banerjee, "Assessment of Ride-Through Alternatives for Adjustable-Speed Drives", IEEE Trans. on Industry Application vol. 35, issue 4, pp. 908 - 916, July-Aug. 1999.
6. K. Lee, T.M. Jahns, D.W. Novotony, T.A. Lipo, W.E. Berkopec, and V. Blasko, "Impact of Inductor Placement on the Performance of Adjustable-Speed Drives Under Input Voltage Unbalance and Sag Conditions", IEEE Trans. on Industry Applications, vol. 42, No. 5, pp. 1230-1240, Sept./Oct. 2006.
7. M. Sullivan, T. Vardell, and M. Johnson, "Power Interruption Costs to Industrial and Commercial Consumers of Electricity", IEEE Trans. on Industry Applications, vol. 33, pp. 1448–1458, Nov./Dec. 1997.
8. A. Z. Van. R. Spee, A. Faveluke and S. Bhowmik, "Voltage Sag Ride-Through for Adjustable-Speed Drives With Active Rectifiers", IEEE Trans. on Industry Applications, vol. 34, issue 6, pp. 1270 – 1277, Nov.-Dec. 1998.
9. J. L. Duran-Gomez, P. N. Enjeti, and B. O. Woo, "Effect Of Voltage Sags on Adjustable Speed Drives-A Critical Evaluation and an Approach to Improve Its Performance", IEEE Trans. on Industry Applications, vol. 35, pp. 1440–1449, Nov./Dec. 1999.
10. J. L. D. Gomez, P.N. Enjeti, A. J. Von,"An Approach to Achieve Ride-Through of an Adjustable-Speed Drive with Fly back Converter Modules Powered by Super Capacitors", IEEE Trans. on Industry Applications, vol. 38, issue 2, pp. 514-522 March-April 2002.
11. L. Palma, P. Enjeti, E. Aeloiza, "An Approach to Provide Ride-Through for ASD Systems with Supercapacitors", IEEE Power Electronics Congress, pp. 182-187, Oct. 2002.

12. F. D. Silva, A. J. J. Rezek, A. A. P Junior, L. E. B. D. Silva, P. C. Rosa, and L. O. M. Reis, "Ultracapacitor-Based Ride-Through System for Adjustable Speed Drives Applied to Critical Process", IEEE conference on Harmonics and Quality of Power, vol. 2, pp. 632-638, 2002.
13. Y.R.L. Jayawickrama and S. Rajakaruna, "Ultracapacitor Based Ride-Through System for a DC Load", IEEE Conference on Power System Technology, vol. 1, pp. 232-237, 2004.
14. S.S.Deswal, Ratna Dahiya, D.K.Jain, "Application of Boost Converter for Ride-through Capability of Adjustable Speed Drives during Sag and Swell Conditions", Proceedings of World Academy of Science, Engineering and Technology, Vol.30, July 2008,pp-899-903.
15. Dahiya. D.K.Jain. Ashok Kumar, R.Dahiya, S.S.Deswal, "Ride-through Capabilities of ASD's Using Ultracapacitors", Proceedings of 8th International Power Engineering Conference (IPEC-07), pp-714-719, Singapore, 2007.